

SE300B

Static Exciter

From Serial # 623559

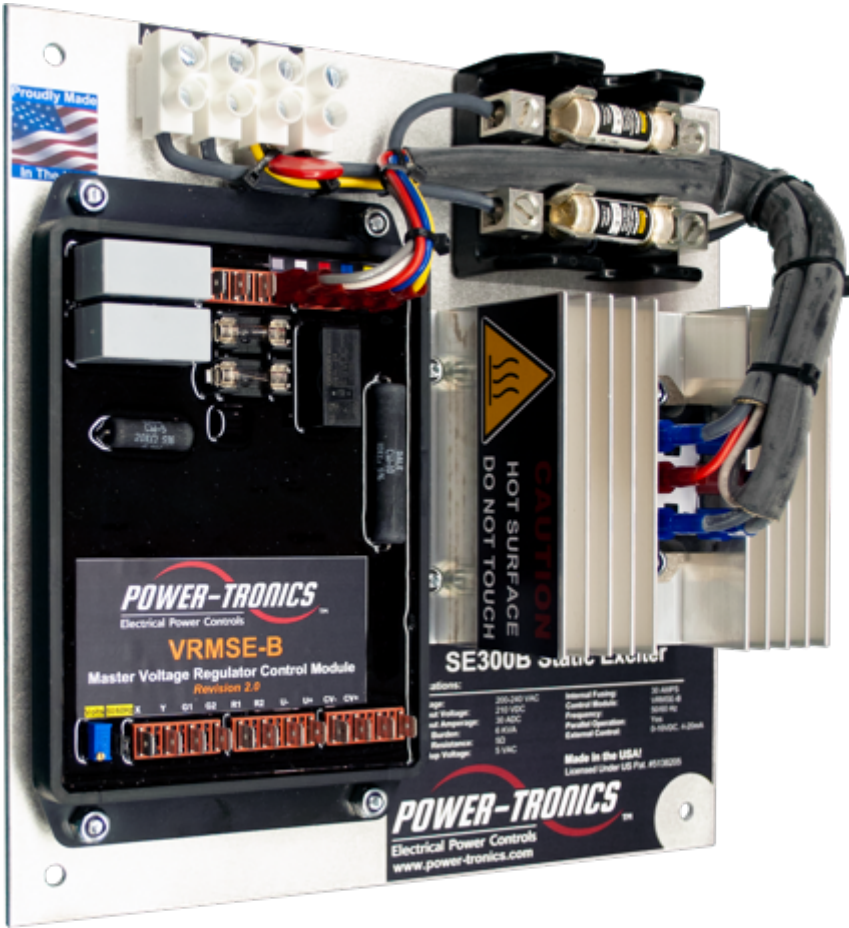

The Power-Tronics SE300B Static Exciter is a self-contained, heavy-duty complete chassis Static Exciter. The SE300B Static Exciter is designed for continuous operation up to 125vdc at 25adc!

The SE300B is uniquely designed to fit in a compact footprint while being passively convection cooled for a long, maintenance-free service life. Because of its unique modular design, the SE300B minimizes downtime should a repair ever be necessary! All serviceable parts are easily removable without the need to remove the chassis from the mounting cabinet or tray.

Over 30 years of field use and design refinement makes the SE300B a time-proven design, utilizing high-reliability components, and a unique modular design to simplify repair. The SE300B is designed to provide a lifetime of service and is specifically built to minimize failures and potential downtime!

The SE300B is capable of parallel operation with other generators or with a utility buss. The VRMSE-B control module includes an internal 0-10VDC or 4-20mA interface module to allow a wide variety of VAR, PF, or other PLC controls to remotely control the unit. An optional motorized potentiometer allows remote operation by dry contact switching or older pulsed-DC control schemes.

Specifications

Input Voltage:	208 - 240vac
Frequency:	50 or 60 Hz
Voltage Regulation:	+/- .25% From NL to FL
Parallel Operation	Yes
Output Voltage Range:	0-210vdc @ 240vac input
Maximum Forcing Output:	210vdc @ 30adc
Rated Continuous Output:	125vdc @ 25adc
Minimum Field Resistance:	5Ω @ 125vdc output
Min Residual Build up Voltage:	5vac
Under Frequency Protection:	Yes, VPH reduction
Physical Size:	10 x 10 x 4 in.
Weight:	4 lb.
Integrated Control Module:	VRMSE-B
Optional Control Module:	VRMSE-B/MAN
Internal Build-Up Provisions:	Yes, Residual AC Flash
Repairable:	Yes
Internal Protection:	Fuses, cartridge type
External Voltage Adjustment:	Yes
System Operating Indicator:	Yes
Optional External Controls	Yes
Integrated 0-10VDC / 4-20mA Interface:	Yes

Table of Contents

Introduction and Functional Description:.....	3
Determining Application Sizing:.....	4
Common 12-Lead Generator Wiring Diagrams:.....	6
Included Parts & Accessories:.....	7
Mounting Dimensions & Chassis Ground:.....	8
Input Power & Field Connection Diagram:.....	9
VRMSE-B Control Module:.....	10
VRMSE-B/MAN Control Module:.....	11
Standard Control Wiring Diagram:.....	12
Parallel Control Wiring Diagram:.....	13
Fully Automatic Remote Adjustment Wiring Diagram:.....	14
Automatic / Manual Selectable Remote Adjustment Wiring Diagram:.....	15
Adding an External Manual Battery Flash:.....	16
Initial Setup and Commissioning:.....	17
Optional Power-Tronics Add-On Modules:.....	18
Application Troubleshooting:.....	19
Bench Check Procedures:.....	20
Installation Warranty Form:.....	21
Product Warranty Certificate:.....	22

For Technical Support:
Visit our website at: www.power-tronics.com
Call Us at: (830) 895-4700

Introduction and Functional Description

Caution: Read This Installation Manual Carefully and Entirely!

Warning: Do not use digital equipment to read voltage, Hz, or amperage during this installation. Use only Analog sensing equipment! Failure to do so may result in damage to equipment or in personal injury!

ALWAYS perform all setup procedures off-line

ALWAYS wear eye protection

ALWAYS strip wire insulation properly or use insulated connectors

ALWAYS use analog metering equipment when setting up the regulator

ALWAYS ensure the static exciter receives ample airflow

ALWAYS use adequate fusing

NEVER hold the static exciter in your hand or lap when energized

NEVER install the static exciter in a place it can be exposed to the elements or moisture

NEVER mount the static exciter over a screw, bolt, rivet, seam, or other fastener

NEVER remove the regulator cover while the unit is in operation

NEVER insert a screwdriver or other object under the regulator cover

NEVER touch any exposed part of the SE300B during operation

NEVER install a switch in the DC portion of the static exciter's wiring

NEVER USE A DIGITAL FREQUENCY METER (*It can give a false reading!*)

Functional Description

The SE300B Static Exciter is the result of over 30 years of engineering efforts and offers high-demand features at a competitive price point. The SE300B is a time and field-proven design and is engineered to greatly simplify setup while offering extreme reliability. When properly installed, the SE300B Static Exciter is designed to provide a lifetime of service.

A Generator voltage regulator has several automated tasks it must perform in order to provide reliable, clean, and regulated electricity. It must build-up the generator, regulate the terminal voltage within its design specifications, and protect both itself and the generator should a fault situation arise.

The SE300B Static Exciter is designed to replace older obsolete static exciters or rotating exciters with a minimum of connections and a minimum of required installation space. The SE300B Static Exciter contains an internal flashing circuit for guaranteed buildup, internal filter for voltage sensing, internal field-replaceable 30A fusing, and internal DC field noise suppression. The SE300B is also designed to be user-serviceable should a problem arise. Fuse or rectifier replacement in the field takes only minutes, thanks to the unique modular design of the SE300B.

Due to its extreme simplicity, the SE300B Static Exciter is uncommonly reliable and offers features and regulation accuracy usually only offered by much more complicated and often much more expensive static exciters.

For Technical Support:

Visit our website at: www.power-tronics.com

Call Us at: (830) 895-4700

Determining Correct Application Sizing

The SE300B Static Exciter is designed for use with 208-240VAC input. It contains internal suppression for use with brush-type generator sets. Before installation, it is necessary to verify that the SE300B is the correct product for your application.

To determine if the SE300B is the correct product for your generator you need to know any two of the following 3 specifications from the rating plate of your generator:

- 1: Exciter Field Voltage (in DC Volts) [Generally given in full load Voltage on nameplates]
- 2: Exciter Field Resistance (in Ohms) [**See Note Below**]
- 3: Exciter Field Amperage (in DC Amps) [Generally given in full load Amps on nameplates]

Using the specifications obtained from your generator exciter, verify that your generator fits the specifications below:

- Exciter full load voltage is 125VDC or less, and your exciter field resistance is 5Ω or greater.
-



WARNING: BRUSH AND SLIP RING CONNECTION PROBLEMS ARE THE #1 SOURCE OF VOLTAGE CONTROL PROBLEMS AND FAILURE OF STATIC EXCITERS!!! DO NOT INSTALL THE SE300B IF THE BRUSHES AND/OR SLIP RINGS ARE NOT IN EXCELLENT CONDITION!!!

STOP AND CORRECT BRUSH AND SLIP RING CONNECTION PROBLEMS IF ANY OF THE FOLLOWING CONDITIONS ARE PRESENT:

- GROOVES IN SLIP RINGS
- ROUGH SLIP RING APPEARANCE OR GHOSTING (CHATTERING)
- OIL CONTAMINATION ON BRUSHES OR SLIP RINGS
- DULL, ROUGH, STRIPED, PITTED, OR METALLIC APPEARANCE OF BRUSH FACES
- FIELD RESISTANCE MEASURED BETWEEN SLIP RING BRASS AND FIELD RESISTANCE MEASURED BETWEEN FIELD LEADS EXCEEDS 1-2% DIFFERENCE

For Technical Support:

Visit our website at: www.power-tronics.com

Call Us at: (830) 895-4700

Note about Field Resistance:

- When measuring field resistance on a brushless generator, simply measure the resistance of the exciter field through your field leads with a multimeter.
- When measuring field resistance on a brush-type generator, measure the resistance through both the field leads as well as directly on the slip rings themselves. **The readings you obtain should ideally be the same, but no more than 1% difference.** If you show more than 1% difference in reading your generator has brush and ring contact problems and will need cleaning or maintenance before installing the SE300B. **Failure to correct brush and ring contact problems will result in severe damage to the voltage regulator as well as possible PERMANENT damage to the slip rings themselves!** NEVER use emery cloth, carborundum stones, “comm sticks”, or Tuner cleaner to dress or clean slip rings. They will make a bad problem much, much worse! Only use Garnet or Flint sandpaper and clean with a clean rag soaked with Acetone for best results!

If you do not have any of the specifications of your generator’s exciter, or if you don’t know where to start when trying to determine your exciter specs, please see the section below for instructions on measuring and calculating your exciter specifications.

- Measure your exciter field resistance using a multimeter on your field leads. Record this value. If you have a brush-type generator, also take a resistance reading on your slip rings: the value you obtain on the slip rings should be no more than 1% difference from the value you obtained through the field leads.
- Next, start and run the generator and apply 12V from a battery through your field leads and record the AC voltage produced by the generator. To determine your full load exciter field voltage, use the following formula:

$$E_{Exc.} = \frac{E_{Gen.Conf.}}{\left(\frac{E_{Gen.Output}}{E_{Battery}} \right)} * 2$$

Where $E_{Gen.Conf.}$ is your Generator’s configured voltage (e.g.: 120, 208, 240, 480V, etc.), $E_{Gen.Output}$ is your recorded output voltage, and $E_{Battery}$ is your battery voltage (12V usually).

- Next, calculate your maximum exciter field amperage using your measured field resistance and your calculated exciter voltage using the following formula:

$$I = \frac{E}{R}$$

Where I is your maximum exciter field current, E is your calculated field voltage from the above formula, and R is your measured field resistance.

Using the values you just measured and calculated, see the specifications on the previous page to determine whether the SE300B is the correct product for your application.

For Technical Support:

Visit our website at: www.power-tronics.com

Call Us at: **(830) 895-4700**

Common 12-Lead Generator Wiring Diagrams

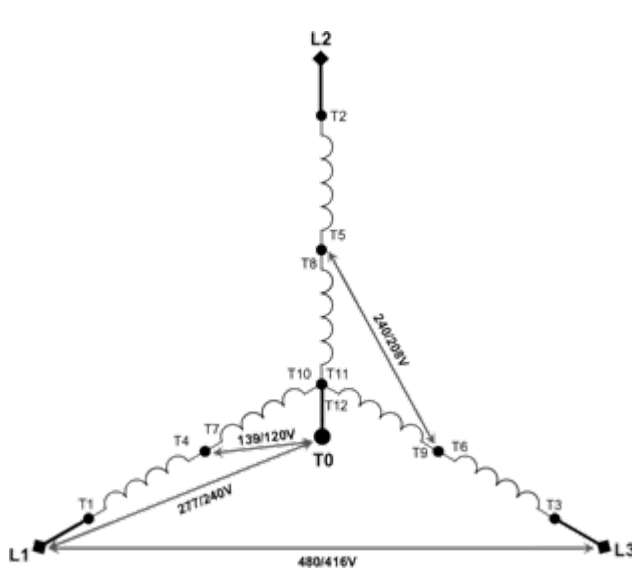

Series Wye (416/480V 3 ϕ)

Voltage L-L: 416/480V
 Voltage L-N: 240/277V
 Voltage CT – N: 120/139V

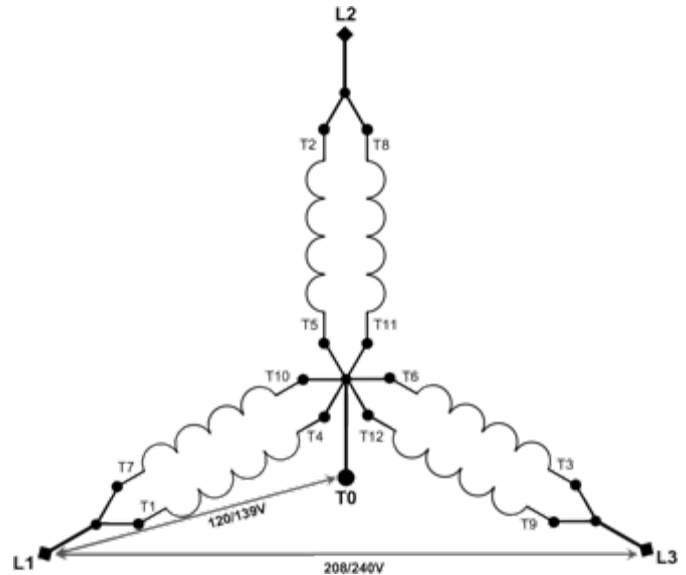

Parallel Wye (208/240V 3 ϕ)

Voltage L-L: 208/240V
 Voltage L-N: 120/139V
NOTE: 208V is Standard Voltage

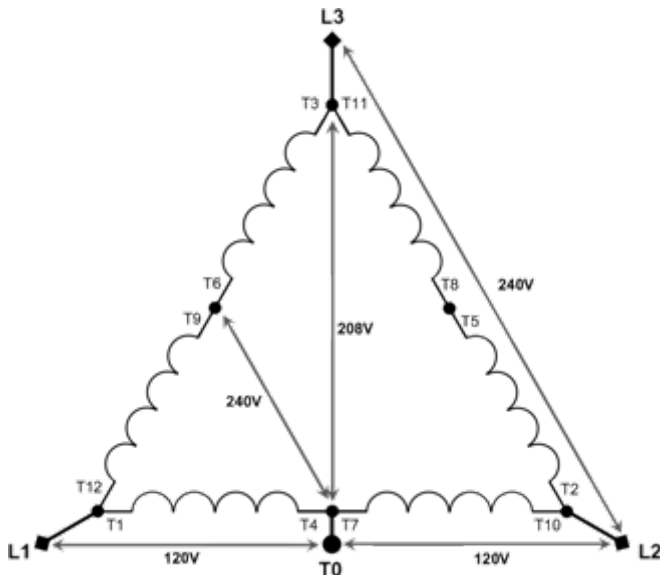

Series Delta (240V 3 ϕ)

Voltage L-L: 240V
 Voltage L1/L2-N: 120V
 Voltage L3 – N: 208V
NOTE: L3-N is a "High Leg"
 208V instead of 120V!

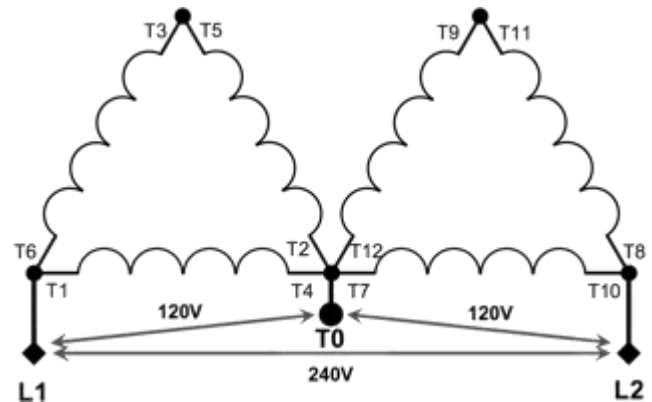

Double-Delta (120/240V 1 ϕ)

Voltage L-L: 240V
 Voltage L-N: 120V
 Preferred Single-Phase Connection.
 Don't Use Zig-Zag if Possible.
NOTE: Derate generator by 1/3 rated
 capacity when using this connection!

For Technical Support:
 Visit our website at: www.power-tronics.com
 Call Us at: (830) 895-4700

Included Parts & Accessories

The SE300B Static Exciter includes the following parts and accessories to ensure a quick and easy installation:

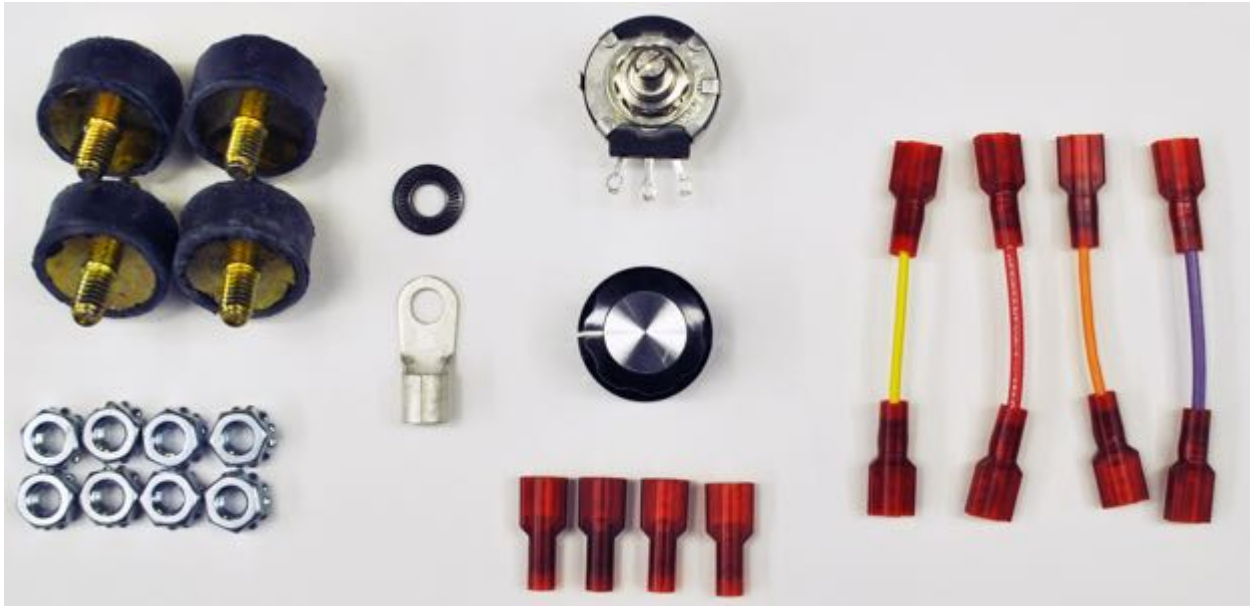

Included Parts List:

- | | |
|--|---------------|
| <input type="checkbox"/> Vibration Isolators | Qty: 4 |
| <input type="checkbox"/> 1/4-20 Self-Locking Nuts | Qty: 8 |
| <input type="checkbox"/> #16-14AWG Compression Terminal | Qty: 1 |
| <input type="checkbox"/> 1/4" Bellville Washer | Qty: 1 |
| <input type="checkbox"/> 100K 2W Long-Life Potentiometer | Qty: 1 |
| <input type="checkbox"/> Panel Knob for Potentiometer | Qty: 1 |
| <input type="checkbox"/> #22-18AWG .250 Female Terminals | Qty: 4 |
| <input type="checkbox"/> Yellow Jumper Wire (Factory Installed) | Qty: 1 |
| <input type="checkbox"/> Red Jumper Wire | Qty: 1 |
| <input type="checkbox"/> Orange Jumper Wire | Qty: 1 |
| <input type="checkbox"/> Purple Jumper Wire | Qty: 1 |

For Technical Support:

Visit our website at: www.power-tronics.com

Call Us at: (830) 895-4700

Mounting Dimensions & Chassis Ground

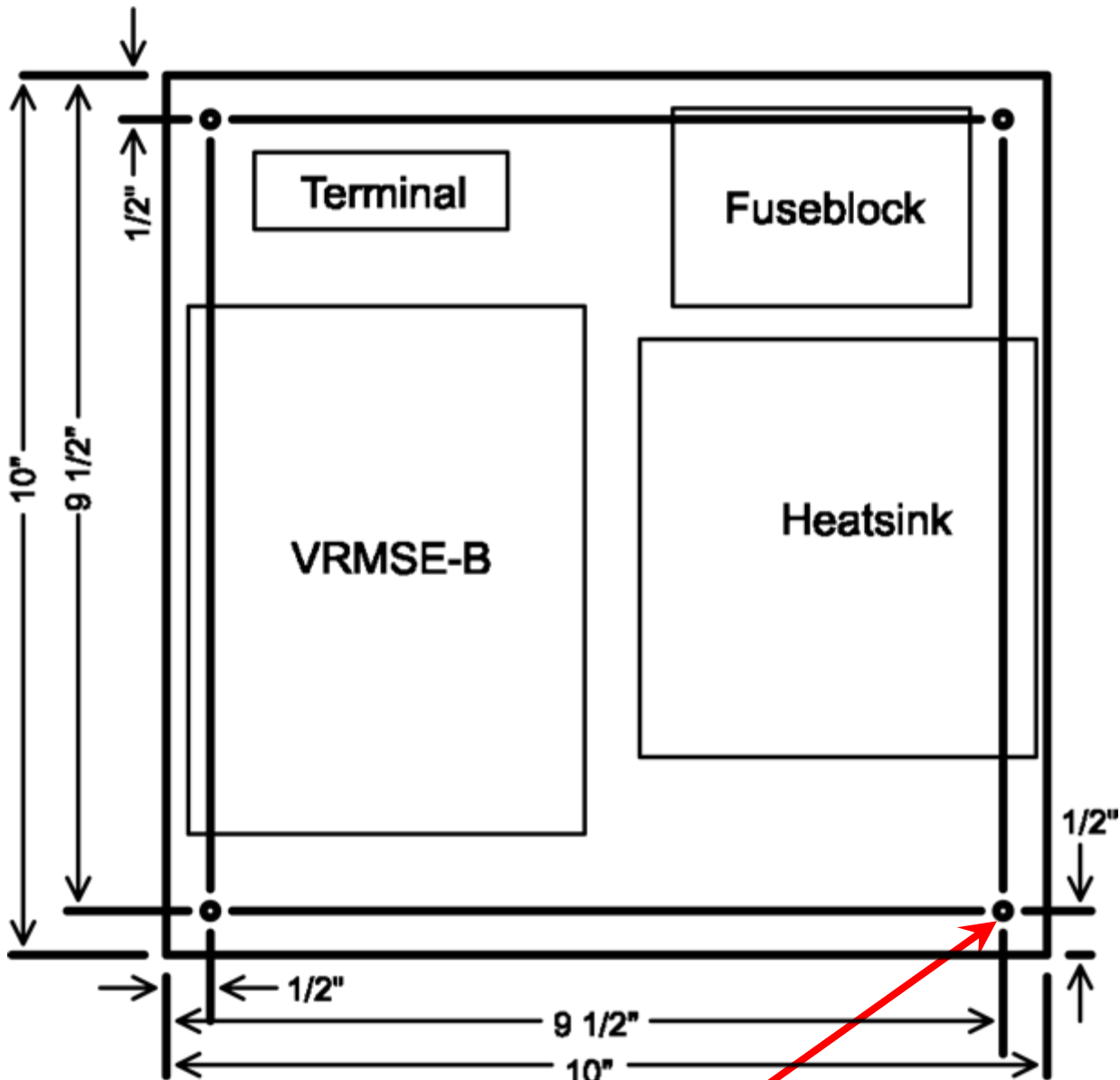

**Chassis Should Be
Grounded
For Safety!!!**

Use Supplied Compression Terminal
And Bellville Washer Provided In
Accessories Kit

Attach to Bottom Right Mounting Point.

Torque to 125 in•lbf (15N•M)



For Technical Support:

Visit our website at: www.power-tronics.com

Call Us at: **(830) 895-4700**

Input Power & Field Connection Diagram

(See page 10 for control wiring information)

The SE300B is a Full-Wave rectified static exciter, which allows a maximum of 210VDC at 30 ADC with an input voltage of 240VAC.

This product is typically used on slip-ring generators with full load field voltages of 125VDC or less and full load exciter field amperages between 5 and 25ADC.

Note that the maximum input voltage to the SE300B Static Exciter is 240VAC! DO NOT input 277VAC into the SE300B! Severe damage to the unit will result! For use on 480V systems, use a **480-240V step-down transformer rated at 6KVA** or connect the regulator to the winding center taps T7 and T9 (See Page 6).

Connecting the input of the SE300B to 2 different phases of the generator as shown in the diagram below will result in greater regulation accuracy than when connecting line-neutral.

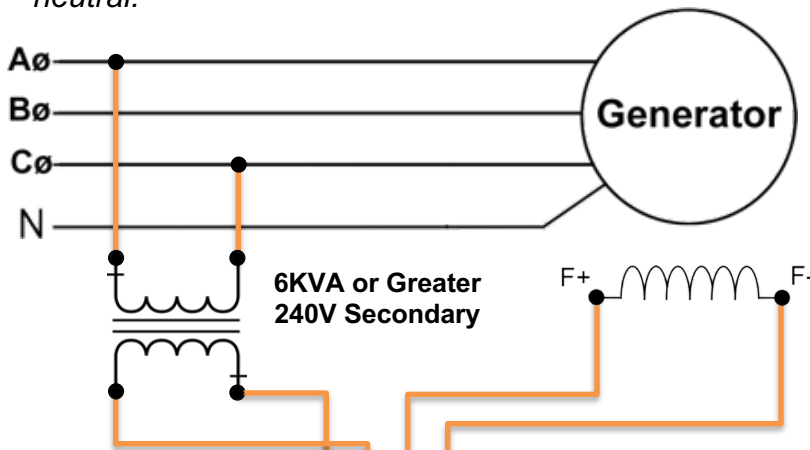

Diagram Assumes a 208-240V Generator For 480V Generators, use a 6KVA (or larger) Transformer with a 240V Secondary OR Connect to the Generator winding center taps at T7 and T9.

NOTE:

Diagram shows an isolation transformer, which is recommended for ALL installations. An isolation transformer will save your engine bearings should the rotor ever short to ground!

Note Polarity Marks On Transformer!

NEVER install a switch or breaker on the DC or Exciter side of the voltage regulator!

Only install a switch or disconnect on the AC Side of the regulator!

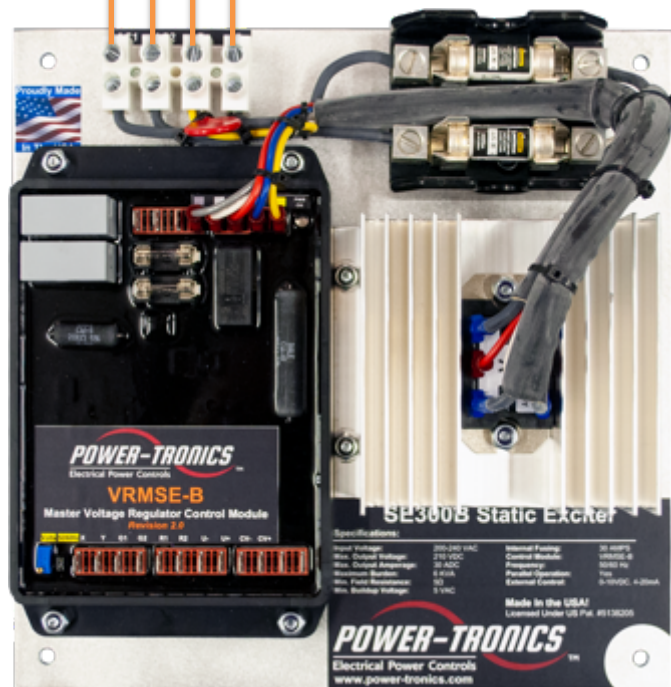

See Pages 12-15 for Control Wiring Diagrams

For Technical Support:
Visit our website at: www.power-tronics.com
Call Us at: (830) 895-4700

VRMSE-B Control Module

The VRMSE-B Control Module is an integrated device designed to replace multiple discrete components in previous generations of Static Exciters. It incorporates an Automatic Voltage Regulator, AC Filtering, Automatic Residual AC Flashing Circuit, and integrated 0-10VDC / 4-20mA Interface Module.

The unitary design simplifies installation in the field, and greatly simplifies replacement if a fault occurs with the control module. The unit has 4 color-coded wires with quick-connect terminals, and can be quickly swapped out in under 5 minutes without the need to remove the chassis from its enclosure or tray.



Status
LED

Internal Voltage
Adjustment
25 Turn Pot!

50/60Hz
Selection Jumper
Remove for 50Hz
Operation

0-10V/4-20mA
Selection Jumper
**Remove for 0-10V
Operation**

Terminal Descriptions:

Colored Terminals:

Chassis Wiring (Color-Coded)

X & Y:

Paralleling CT Input
Factory-Installed Yellow Jumper

G1 & G2:

Gate Enable Pins
Short G1 & G2 To Run Exciter
**Switch or Relay Recommended
If No Switch, Install Red Jumper**

R1 & R2:

Remote Adjustment Input

U- & U+:

Output From Internal 0-10V
Interface Module

CV- & CV+:

Input for 0-10V or 4-20mA Signal

For Technical Support:

Visit our website at: www.power-tronics.com

Call Us at: **(830) 895-4700**

VRMSE-B/MAN Control Module (Factory Option)

The VRMSE-B/MAN Control Module is an optional control module featuring a passive regulation circuit and manual stability control. It incorporates an Automatic Voltage Regulator, AC Filtering, Automatic Residual AC Flashing Circuit, and integrated 0-10VDC / 4-20mA Interface Module.

The VRMSE-B/MAN is sometimes a better choice for hydro-turbine installations or any application where aggressive control of the exciter is desired. Due to the way the different regulation circuitry functions, the VRMSE-B/MAN is often better suited for erratic grid conditions or generators with slow magnetic characteristics.



Terminal Descriptions:

Colored Terminals:

Chassis Wiring (Color-Coded)

X & Y:

Paralleling CT Input
Factory-Installed Yellow Jumper

G1 & G2:

Gate Enable Pins
Short G1 & G2 To Run Exciter
Switch or Relay Recommended
If No Switch, Install Red Jumper

R1 & R2:

Remote Adjustment Input

U- & U+:

Output From Internal 0-10V
Interface Module

CV- & CV+:

Input for 0-10V or 4-20mA Signal

Status
LED

Internal Voltage
Adjustment
25 Turn Pot!

Internal Stability
Adjustment
25 Turn Pot!

50/60Hz
Selection Jumper
Remove for 50Hz
Operation

0-10V/4-20mA
Selection Jumper
**Remove for 0-10V
Operation**

For Technical Support:

Visit our website at: www.power-tronics.com

Call Us at: (830) 895-4700

Standard Control Wiring Diagram

This wiring diagram shows the default control wiring configuration for the SE300B. Power wiring is shown on Page 9.

This diagram assumes an isolated (unit/islanded) operating environment with manual remote adjustment.



VRMSE-B
Voltage Regulator Control Module
Revision 3.0
For Power-Tronics Full-Wave Static Exciters
POWER-TRONICS
Electrical Power Controls

Proudly Made
In The USA

NOTE:
Yellow Jumper is
Factory Installed!

NOTE:
If not using a switch,
Install Red Jumper
from Accessory Kit

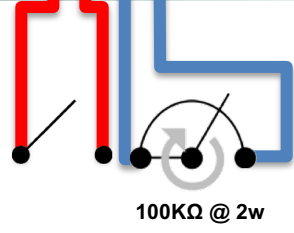

NOTE:
It is not necessary
to jumper terminals
R1 and R2 if not
using the Remote
Voltage Adjustment!

For Technical Support:
Visit our website at: www.power-tronics.com
Call Us at: (830) 895-4700

Parallel Control Wiring Diagram

To use the SE300B Static Exciter in a parallel configuration either with another generator or with a buss such as a utility, use the diagram below for proper hookup with the SE300B. **Power wiring is shown on Page 9.**

This diagram assumes a paralleled operating environment with manual remote adjustment.

NOTE: Power-Tronics products parallel using the Reactive Droop compensation method. This allows our products to parallel with existing systems easily while also allowing islanded operation with the flip of a switch. **When initially installing the droop resistor, set it for approximately 7Ω (2Ω for VRMSE-B/MAN control modules) before final adjustment later.** If the droop is excessive when load testing, reduce the resistance a bit at a time until satisfactory droop is achieved. **CT should be sized at 25-35VA capacity!**

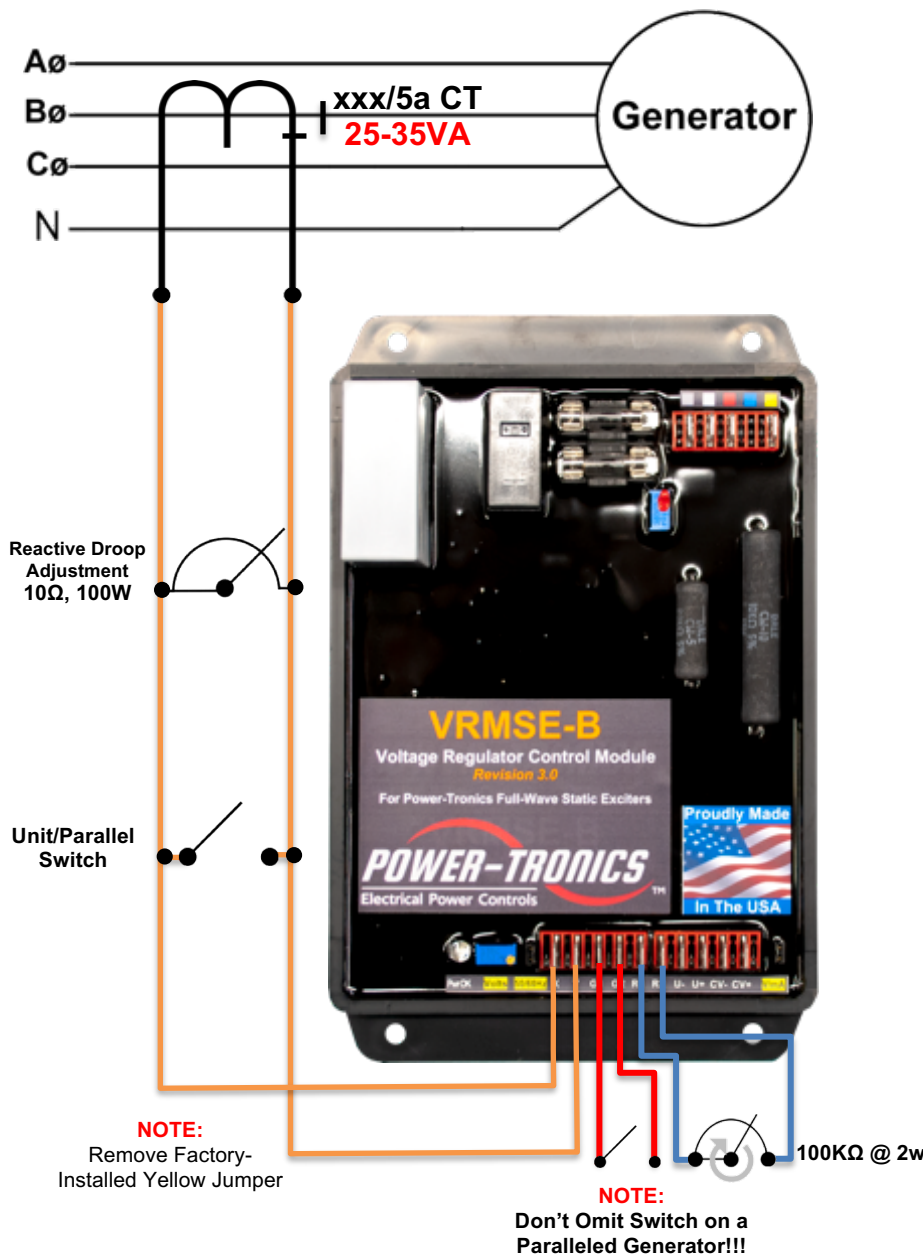

If using the internal 0-10VDC Interface module, See Pages 14-15 for Control Wiring Diagrams

NOTE:
Don't Omit Remote Adjustment on a Paralleled Generator!!!

For Technical Support:
Visit our website at: www.power-tronics.com
Call Us at: (830) 895-4700

Fully Automatic Remote Adjustment Wiring Diagram

This wiring diagram shows ONLY the control wiring configuration for fully-automatic Remote Control of the SE300B. **Control wiring is shown on Pages 12 and 13.**

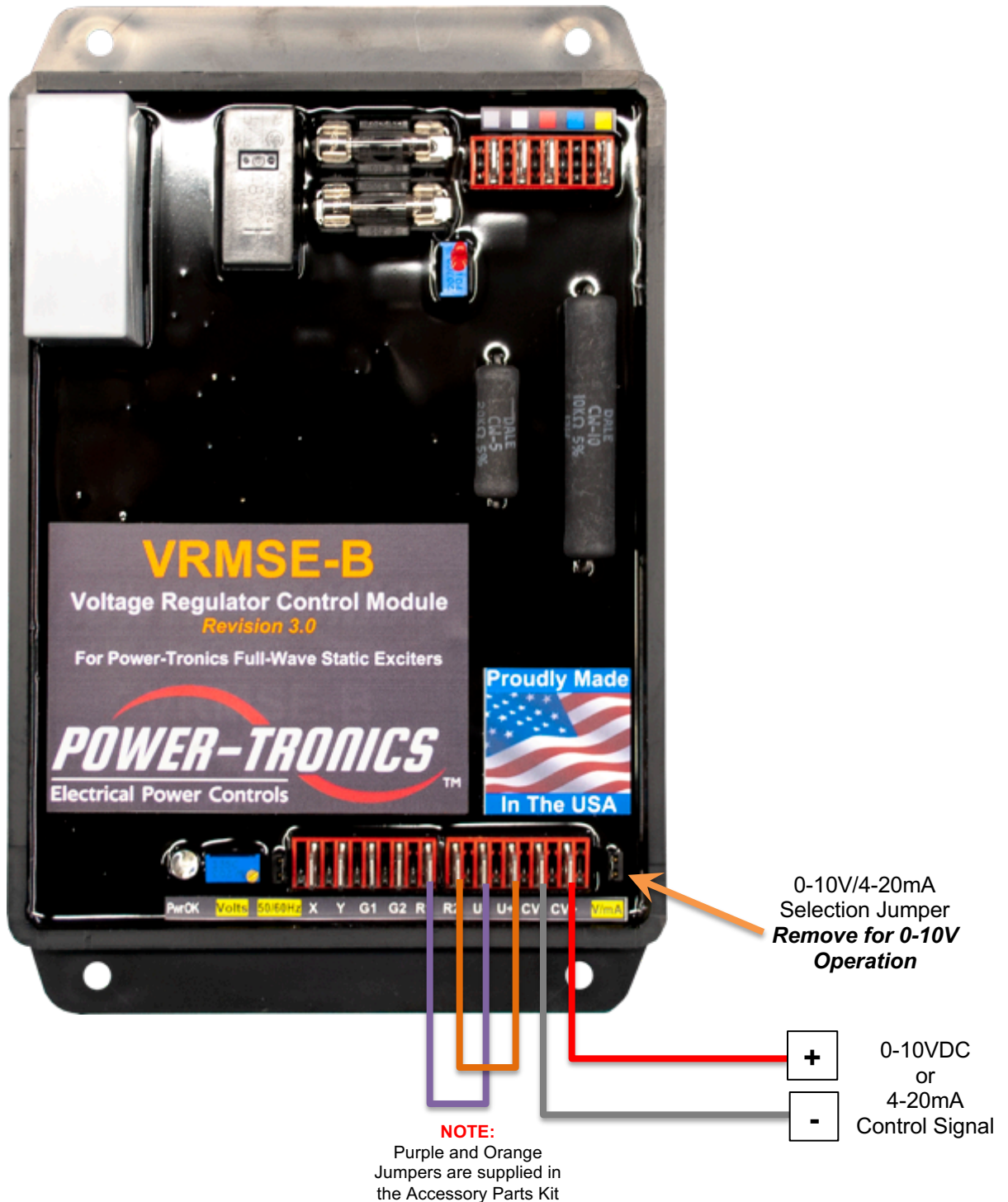

For Technical Support:
 Visit our website at: www.power-tronics.com
 Call Us at: (830) 895-4700

Automatic / Manual Selectable Remote Adjustment Wiring Diagram

This wiring diagram shows ONLY the control wiring configuration for fully-automatic Remote Control of the SE300B. **Control wiring is shown on Pages 12 and 13.**

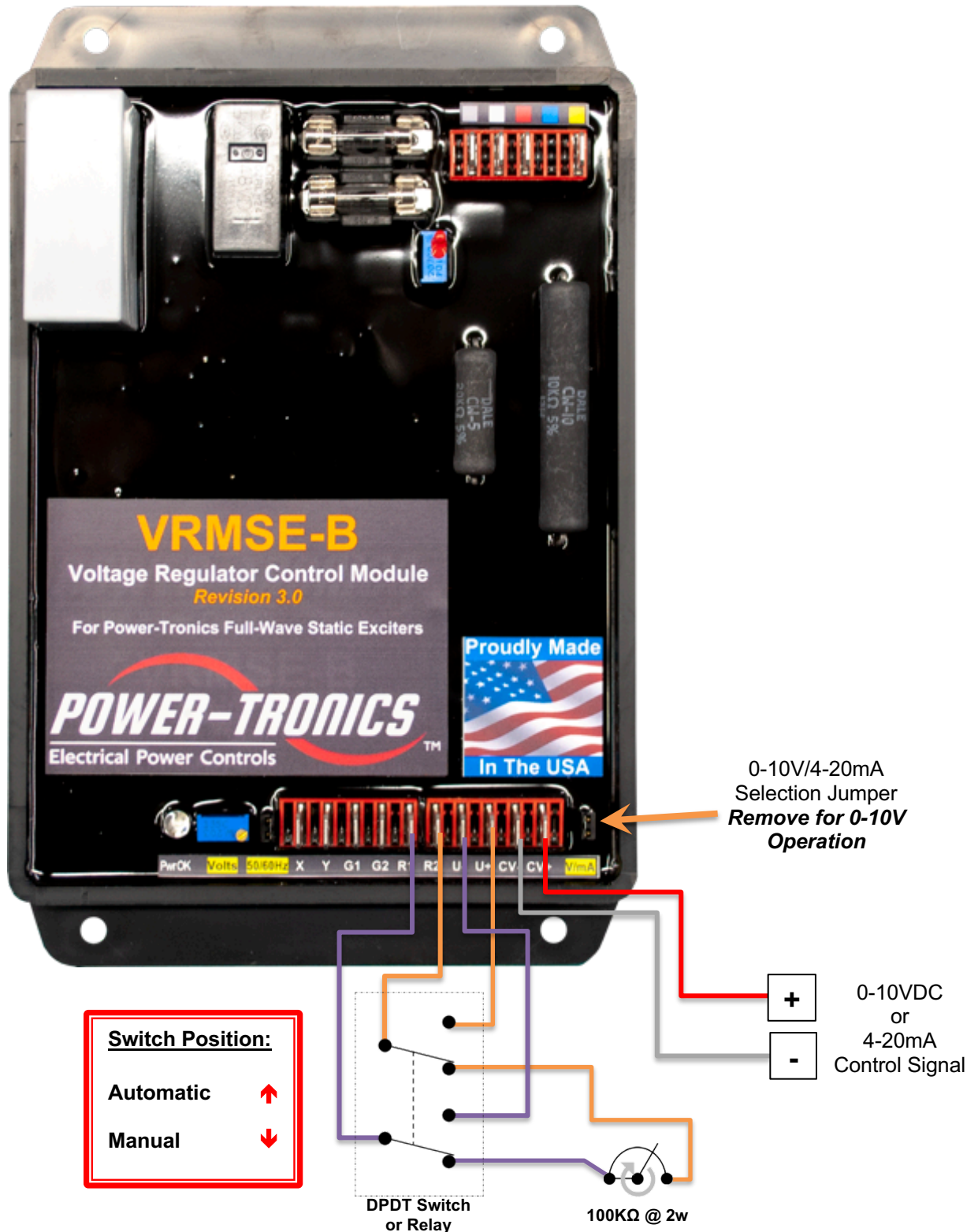

For Technical Support:
Visit our website at: www.power-tronics.com
Call Us at: (830) 895-4700

Adding an External Manual Battery Flash

The diagram below shows how to add a manual battery flash circuit to the SE300B.

If you prefer an automatic battery flash solution, the Power-Tronics ABF10 Automatic Flashing Module provides an automated battery flashing solution using a standard 12 or 24V isolated battery source.

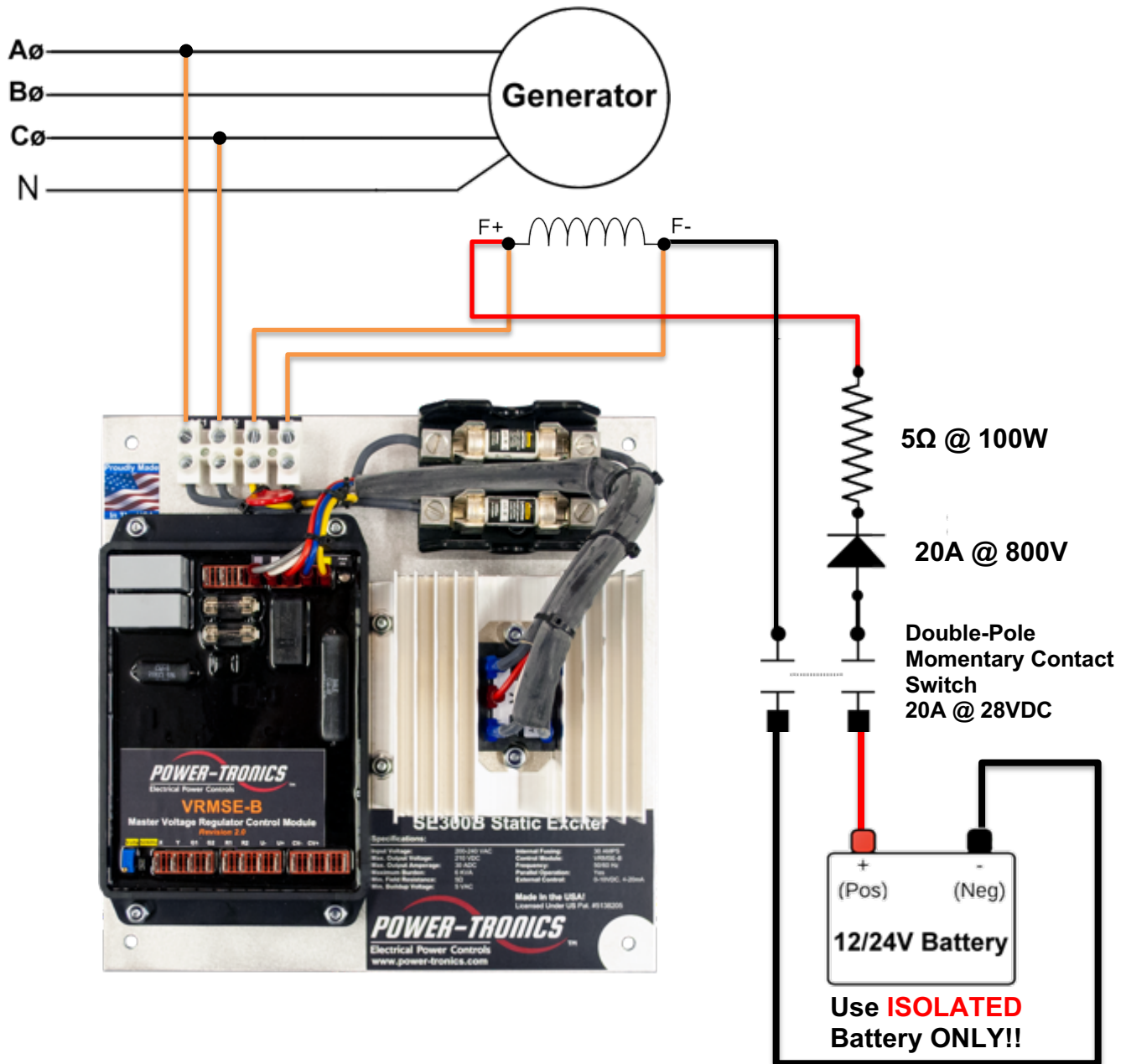

For Technical Support:
 Visit our website at: www.power-tronics.com
 Call Us at: **(830) 895-4700**

Initial Setup and Commissioning

1. Install the SE300B and wire according to the correct wiring diagram and control wiring diagram (**Pages 9-15**).
2. If installing the SE300B on a brush-type generator, verify that the brushes and brush riggings are isolated, ungrounded, and connected **ONLY** to the SE300B.
3. If operating on a 50Hz generator, remove the 50/60Hz Selection Jumper on the VRMSE-B.
4. Turn the internal voltage control (VOLTS) on the VRMSE-B Control Module 15 or more turns counter clockwise (left) or until you hear the screw click. This procedure is necessary in case the original factory settings have been altered.
5. If you are using a remote voltage adjustment, set it at 50% of adjustment.
6. If the generator is to be paralleled, set the droop resistor between 6Ω and 10Ω (2-3Ω for models fitted with the VRMSE-B/MAN control module).
7. Start up the prime mover and bring up to operating speed and turn on the regulator switch (if used).
8. Set the internal voltage adjustment (VOLTS) on the VRMSE-B Control Module to the desired voltage setting for the generator output by turning the adjustment screw clockwise (right). If your unit is fitted with the VRMSE-B/MAN control module, adjust the stability adjustment (STAB.) clockwise (right) to reduce voltage pulsation/oscillation. Be aware that terminal voltage will rise slightly. Keep in check with the internal voltage adjustment.
Note that the adjustment potentiometers are 25 turns!!
9. Place the generator on line and observe the frequency and voltage.
10. If the generator is being paralleled, measure the droop during loading and adjust the droop resistor as necessary. Reducing droop resistor resistance will reduce droop.
NOTE: Loading the generator with a purely resistive load-bank may cause undesirable droop characteristics such as no droop, very slight droop, or even rising terminal voltage. Measure droop with a mixed load for best results.
11. If paralleling and the terminal voltage rises or excessive amperage exportation occurs during loading with a mixed load connected, reverse the CT leads and try again.
12. If using the internal 0-9VDC interface module, manually vary the input voltage signal to observe the behavior of the exciter in response to a control voltage change. By default the unit ships factory preset for full range from 0-10VDC (Effective range +/-15VAC from 240VAC setpoint).
13. If your external control device uses a +/-9V or +/-10V control signal, you can still use it with the VRMSE-B's internal interface module by manually setting a +5V offset in your control scheme. The unit will recognize 0-10V control signals and will ignore any negative control signals.
14. Observe voltage regulation during no-load and full-load conditions. Once the voltage is set and regulating characteristics are satisfactory the installation procedure is complete.

For Technical Support:

Visit our website at: www.power-tronics.com

Call Us at: **(830) 895-4700**

Optional Power-Tronics Add-On Modules

Power-Tronics offers an array of optional add-on modules for the SE300B Static Exciter. For more information on any of the modules below, visit our online catalog at:

www.power-tronics.com

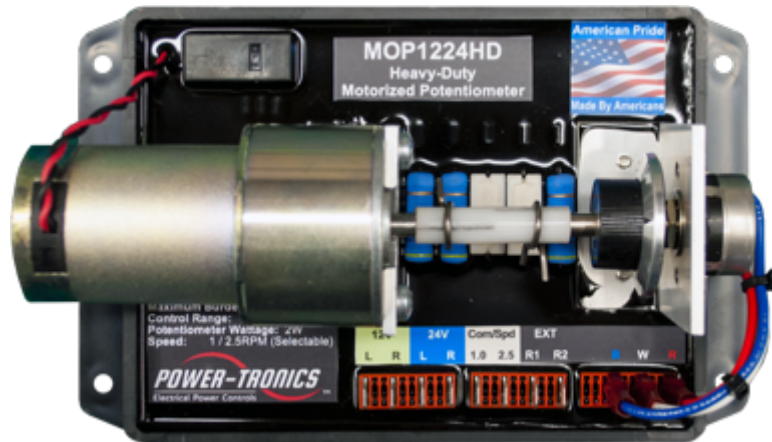

MOP1224HD

Motorized Potentiometer

Allows the SE300B to be externally controlled by older automated controllers using pulsed signals or dry contacts for control!



HVD2

High Voltage Disconnect

Saves your generator and connected equipment from runaway voltage conditions! Disconnects power to the voltage regulator instantly in the event of high voltage!



ABF10

Automatic Battery Flash Module

Adds Automatic Battery Flash to installations with low residual or requiring guaranteed buildup!

For Technical Support:

Visit our website at: www.power-tronics.com

Call Us at: (830) 895-4700

Application Troubleshooting

Problem:

Possible Cause

No Voltage	1 3 5 7 9 11 13 15 20 21
Pulsating Voltage	4 5 6 12 16
Flickering Voltage	4 6 7 14 21 22
High Voltage	6 7 8 9 12 13 17 18 20 21 22
Voltage Drop on Load	5 8 10 12 16 23 24
Low Voltage	5 8 12 13
Poor Voltage Regulation	2 4 10 12 13 16 23 24
No Voltage Control	13 19 20 21 22 23 24

Possible Causes:

1. Residual input voltage to the exciter is below 3.5vac or fuses are open on the chassis or the regulator.
2. Unbalanced generator load.
3. Open exciter field or defective generator.
4. Non linear load or defective connection in exciter field.
5. Open diode in exciter or shorted rotor in generator.
6. Loose component in voltage regulator.
7. Loose wiring connections.
8. Input voltage to regulator is too low.
9. Exciter field is grounded.
10. Non linear load or wrong selection for regulator hookup.
11. Exciter fields are reversed.
12. Wrong selection of regulator wiring configuration.
13. Defective voltage regulator.
14. SCR or Inverter drive effecting generator waveform.
15. Regulator needs external flashing circuit.
16. Isolation transformer is too small.
17. Isolation transformer is needed.
18. Exciter fields are not isolated from other circuits.
19. Input and field circuit are being fed by a common cable or conduit.
20. Incorrect hookup or wiring.
21. Poor brush contact to commutator or sliprings.
22. Damaged, pitted, or grooved slip ring surface.
23. Current transformer has reversed polarity or is not shorted during non parallel operation.
24. Input to regulator is from an auxiliary winding and not the generator main stator.

For Technical Support:

Visit our website at: www.power-tronics.com

Call Us at: (830) 895-4700

Bench Check Procedures

1. Wire the SE300B as shown in the figure below.
2. Connect two 120 volt 50 to 150 watt incandescent light bulbs in series to the F+ and F- Terminals.
3. Install a temporary jumper wire between terminals X and Y and another jumper between terminals G1 and G2 on the VRMSE-B Control Module.
4. Turn the internal voltage adjustment (VOLTS) on the VRMSE-B Control Module fully Counter-Clockwise (Left) before beginning the testing procedures below.
5. Input 208-240VAC fused at no more than 5A into the SE300B. **The test light should be OFF.**
6. Slowly turn the internal voltage (VOLTS) adjustment on the VRMSE-B Control Module Clockwise (Right) until the lights glow. **The test light should light to FULL Brightness. NOTE: It may take several turns of the adjustment screw before the lights illuminate!**
7. Slowly turn the internal voltage (VOLTS) adjustment on the VRMSE-B Control Module Counter-Clockwise (Left) until the lights go dark. **The test light should be OFF. NOTE: It may take several turns of the adjustment screw before the lights go dark!**
8. Turn off power and disconnect the SE300B from your power source. Inspect all electronic components on the SE300B to ensure they are isolated from touching any part of the SE300B housing.
9. **If you were able to successfully perform all of these tests, the SE300B is good.**

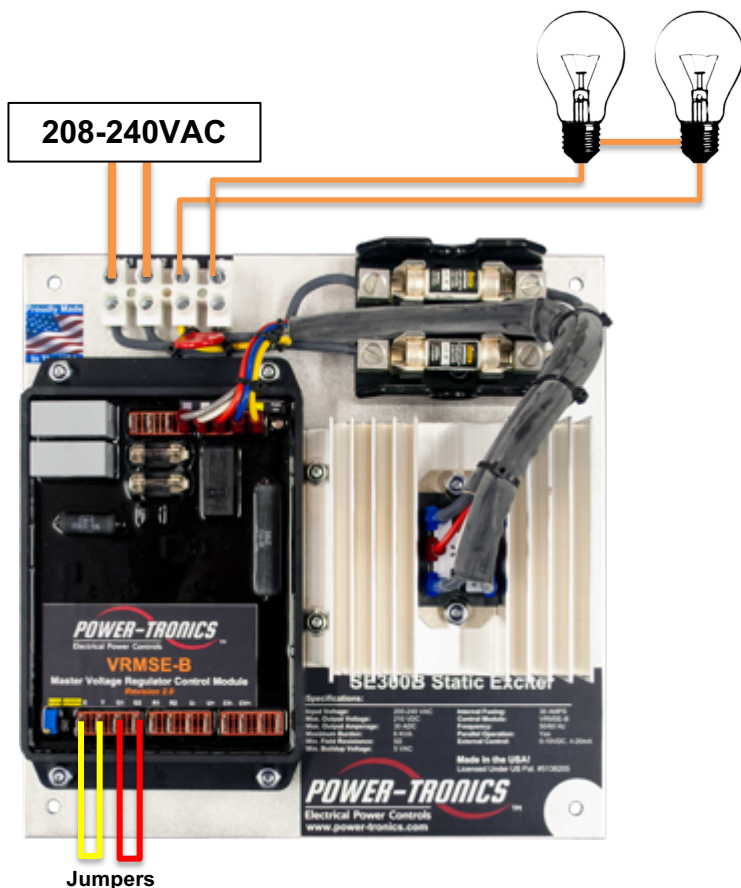

Fuse Replacement Information:

VRMSE-B:

Rating: 5A @ 250VAC

Qty: 2

PTI Part # 5R3-403

Cooper-Bussman Part # BK/GDB-5A

SE300B:

Rating: 30A @ 600VAC

Qty: 2

PTI Part # 5R3-466

Cooper-Bussman Part # JJS-30

Mersen Part # A6T-30

For Technical Support:

Visit our website at: www.power-tronics.com

Call Us at: (830) 895-4700

Installation Warranty Form

It is very important that you fill out this form completely when installing a voltage regulator.

This form serves as a history record on the application. This form also contains the information needed by Power-Tronics, Inc., for repair and troubleshooting of any product you may be having problems with.

Failure to fill out this form during installation will result in a cancellation of your warranty coverage! Filling out this form takes only minutes but will save hours or days later on if your product should require service!

Product Model:	Additional Module(s) or Options:
Serial #:	
Date of Installation:	
<u>This Section for Brushless Generators Only</u>	
Exciter Field Voltage:	Exciter Field Resistance:
<u>This Section for Brush-Type Generators Only</u>	
Shunt-Field Voltage:	Shunt-Field Resistance:
Rotor Resistance @ Brush Leads:	Rotor Resistance on Slip-Rings:
Rotor Excitation Voltage:	
<u>Generator Wiring/Usage Information</u>	
Generator Leads (Check One:) <input type="checkbox"/> 12 <input type="checkbox"/> 10 <input type="checkbox"/> 6 <input type="checkbox"/> 4 (3 ϕ) <input type="checkbox"/> 4 (1 ϕ) <input type="checkbox"/> 3	
Generator Wiring Mode (Check One:) <input type="checkbox"/> High-Wye <input type="checkbox"/> Low-Wye <input type="checkbox"/> Series Delta <input type="checkbox"/> Zig-Zag <input type="checkbox"/> Double-Delta <input type="checkbox"/> Single-Phase <input type="checkbox"/> Other	
Terminal Voltage:	Residual AC Voltage:
Rated KW:	Rated KVA:
Primary Load (Please Explain):	
<u>Repair/Warranty Request Information</u>	
Company Name:	
Contact Person:	
Telephone Number:	
Email Address:	
Ship-To Address (City, State, Zip, Country):	
Problem Description/History (Please be detailed!!!):	

For Technical Support:

Visit our website at: www.power-tronics.com

Call Us at: (830) 895-4700

PRODUCT WARRANTY

Power-Tronics, Inc., assumes no liability for damages due to incorrect voltage or other voltage related damages resulting from either output of the generator or input to the generator exciter system. These problems should be protected with external devices provided by the customer such as **fuses, surge suppressors, over/under voltage and frequency controls**.

Power-Tronics, Inc., warranties **only parts and workmanship** of this product for a **period of 3 years from the original date of purchase from Power-Tronics, Inc.** Under warranty, Power-Tronics, Inc. will replace, exchange or repair the defective product **without labor or parts cost to the customer**. Remaining warranty of the original product will be transferred to the replaced or repaired product. To obtain warranty, a copy of the original Installation Warranty Form must be sent in with the defective product, which clearly shows the purchase date and serial number of the defective part. A repair request form must be sent in with the product before repairs will begin. You can obtain this form by contacting Power-Tronics, Inc.

Send repairs to: Power-Tronics, Inc., 2802 Cobbler Ln., Kerrville Texas USA 78028.

Send in repairs only by UPS or FedEx. USPS will NOT deliver to our facility!

Any one of the following conditions will void the warranty:

- ❖ Overheating of the power supply resistor on the printed circuit card.
- ❖ Overheating of the SCR or freewheeling diode.
- ❖ Physical damage to the printed circuit card, housing or components.
- ❖ Unauthorized repair or alteration of printed circuit card.
- ❖ Installation by anyone other than a qualified professional generator service technician.
- ❖ Conductive or corrosive contamination of the circuit card.
- ❖ Removal of our company identification from the product.
- ❖ Removal of any conformal coating of the printed circuit card or components.
- ❖ Overheating of foil on the printed circuit card.
- ❖ Inappropriate or infeasible application.
- ❖ Use with any external device other than manufactured by Power-Tronics, Inc.
- ❖ Failure to fill out the attached warranty card during installation

No other warranty is expressed or implied.

For Technical Support:

Visit our website at: www.power-tronics.com

Call Us at: (830) 895-4700